

BOND FORCE CONTROL
FC
3

T-3002-FC3

Die Bonder & Component Placer

T-3002-FC3 is equipped with wafer table and die ejector system

T-3000-FC3 is designed to work on XY-table only.

flexible
and easy
to use

A precise, high quality, versatile die bonder & component placer with superior ergonomic design and programmable, high accuracy Z-Drive and bonding force control.

fields
of
application

- MCM,
- COB,
- Hybrid,
- Flip-Chip,
- Photonics,
- SMD,
-



Dr. TRESKY AG

CH-8800 Thalwil
tresky@tresky.com

Boehnirainst. 13 Switzerland
www.tresky.com

Excellent performance, ergonomically designed and high reliability makes the T-3002-FC3 ideal for small and medium production, with various development applications.

The automated DC Z-Drive with bond force control enables a high repeatability of bonding parameters.

The overlapping wafer & bonding levels reduce the necessary work - table movement to a minimum. The special automatic focusing facility compensates the difference between the two microscope working levels. Various video-systems are available for alignment (e.g. Flip-Chip).



TRESKY'S unique die ejector system

The advantage of this method is so significant that delicate dies, which needs multiple needle ejector, can be picked-up by the same standard die ejector. This die ejector is suitable especially for all kind of Si, GaAs and InP dies.

Contrary to conventional die bonding methods, separation of the die from the foil ensures through the pull down of the foil, whereas the die supported by the fixed needle remains stationary. Therefore the usual dynamic forces arising through the acceleration of the die and all pick-up tool assembly parts, (vacuum tool, spindle, vacuum connector etc.) do not arise. This property reduces the danger of die failure and surface damage, features higher alignment accuracy between the pick-up tool and die ejector needle as well as increasing pick-up reliability.

The stroke and the speed of the die ejector barrel is easily adjustable and can be done very quickly without use of a tool.

(Die pickup from wafer)

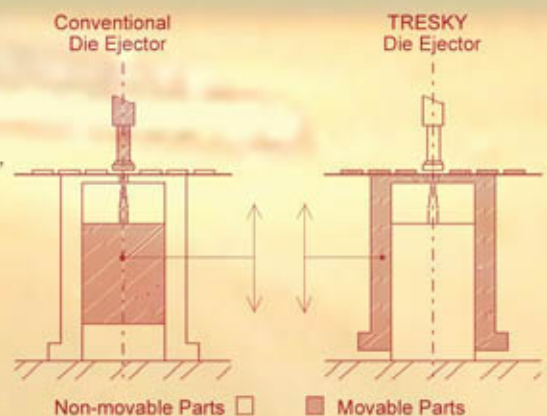

Pick-up all **Si, GaAs, InP** and other dies from wafer

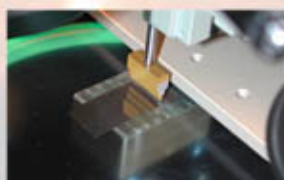

Pick-up delicate components like **Laser Bars** from wafer



Pick-up various component sizes from **Surf Tape**

FC3

VERTICAL UNIT with BONDING FORCE CONTROL & SERVO DRIVE



The FC3 vertical unit incorporates a DC motor servo control with linear encoder and ball bearing spindle. A special pneumatically operated unit enables a disconnection between the drive and vertical guide and permits both, a fully manual or automatic Z-operation at any time. In the automatic mode the system stops at the programmed height or after the programmed force has been reached, and moves upwards after the expiration of the set bonding time. In the manual mode, the Z-axis is locked when the required force is reached. The standard bonding force range varies from 15g to 400g; it can be easily extended up to 2000g or even higher, with the high bond force option for T-3000-FC3.

Memory for pick & place, die bonding, dispensing and stamping programs.

PROGRAM MODES:



PICK & PLACE

This mode serves for die bonding from wafer or of chips loaded in waffle packs as well as placement of all surface mounted devices or others. The tool vacuum switches on/off automatically as soon as the bonding force or certain coordinates have been reached. In the last case the pick-up or placement can be done without imposing any pressure on the component. The coordinates can be determined by program, or the system measures the appropriate thickness and calculates the final coordinates (bond line thickness).

Programmable parameters: Pick-up force, pick-up time, pick-up speed, placement force, placement time, placement speed, bond line thickness, die ejector on/off, die ejector delay, various Z-heights, ...



DISPENSING / STAMPING

The dispensing barrel or stamping tool moves to the working position upon selection of this function. The dispensing / stamping cycle starts either through a press on the foot switch or automatically after the dispensing tip has reached the programmed height.

Programmable parameters: Dispensing time, dispensing height, dispensing clearance height, dispensing up / down speed, stamping glue pick time, stamping pick height, stamping clearance height, stamping time, stamping height, stamping up / down speed, ...



Program +

(PICK & PLACE / DISPENSING / STAMPING)

In this mode a sequence from saved programs can be set together, according to the operator's needs e. g. pick and place, die bonding, dispensing and stamping cycles.

MAIN OPTIONS

ask for Flip-Chip or Eutectic brochure for further information

Flip-Chip IV

The basic part of this unit is a special beam splitter, enabling a simultaneous view of the substrate and the chip bump patterns. The field of view of the integrated zoom lens varies from 0.5 x 0.5 mm to 2.2 x 2.2 mm, or various other zoom ranges.

Eutectic Die Bonding:

Equipment for Eutectic Bonding contains:

- ** Various Heating Plate sizes, up to 500°C, (with or without hot nitrogen circulation).
- ** Custom specific Cover Plate.
- ** Bonding Tool Heating.
- ** Hot Plate and Bonding Tool Temperature Control.
- ** Nitrogen Flow Control.
- ** Scrub Facility.
- ** Pre-Form Placement Unit.
- ** Lead Frames Index Station.

Eutectic Quick Heat:

Small heated stage for fast heating and cooling (RS232 output for PC contr.) with integrated vacuum hold down and hot gas flow capability (max. 450°C)



FEATURES & OPTIONS:

- 1 Bond line thickness (silver glass) facility provides a defined adhesive height (option).
- 2 Scrub for eutectic bonding (option).
- 3 Tool heating for eutectic bonding (option).
- 4 Bonding force control, 360° rotative pick-and-place spindle with vacuum tool.
- 5 Manual XY-work table for substrate, wafer pack, ...

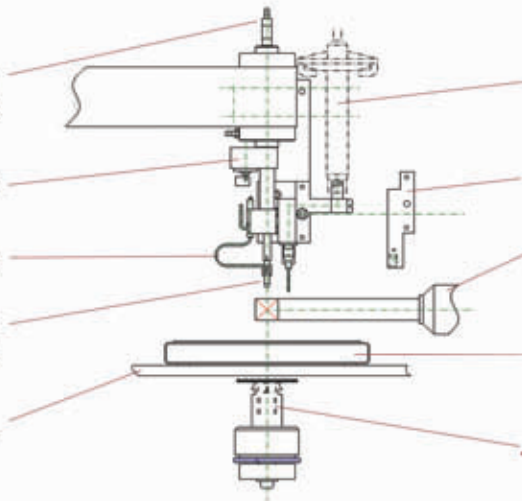

- 6 Dispenser for solder paste or adhesive (moves automatically into working position).
- 7 Stamping head for adhesives (option).
- 8 Flip-Chip optic for alignment of flipped chips, μ BGA or other components (option).
- 9 Heating plate; various versions available for eutectic bonding (option).
- 10 Tresky die ejector.

TECHNICAL DATA:

XY- Movement (placement stage):	220mm x 220mm (manual)
XY- Movement (wafer stage):	220mm x 220mm (manual and only T-3002-FC3 model)
Z- Movement:	95mm (automatic)
Spindle Rotation:	360°
Bond Force (standard range):	15g - 400g (other force ranges possible)
Bond Force (repeatability):	±1g
Z-Measurement resolution:	±0.001mm
Placement Speed:	approx. 5 Sec. for one pick & place cycle (operator / process depending)
Max. PC Board-/ Substrate Size:	400mm x 280mm
Min. Component Size:	0.2mm x 0.2mm (smallest Tresky standard vacuum tool: external \varnothing 0.2 mm for smaller component sizes, contact Tresky Headquarters)
Placement accuracy:	Operator and process depending (with Flip-Chip IV, up to 1 μ m possible)
Connections:	Compressed air 5 - 6 bar / Vacuum 0.6 bar (abs)
Dimensions:	900mm x 800mm x 700mm
Weight T-3000-FC3 / T-3002-FC3:	60kg / 85kg
Voltage:	110V / 220V

Note: All specifications are subject to change without notice

Represented by:

Headquarters:

Dr.TRESKY AG

Tel.: +41 (0)44 772 1941

Boehnrainstr. 13

Fax: +41 (0)44 772 1949

CH-8800 Thalwil

email: tresky@tresky.com

Switzerland

www.tresky.com